A

ACC

ACC

C

SECTION ACC

ACCELERATOR CONTROL SYSTEM

CONTENTS

D

E

PRECAUTION	2	Exploded View	3	F
PRECAUTIONS	2	Removal and Installation	3	
Precaution for Supplemental Restraint System (SRS) "AIR BAG" and "SEAT BELT PRE-TENSIONER"	2	SERVICE DATA AND SPECIFICATIONS (SDS)	5	G
REMOVAL AND INSTALLATION	3	SERVICE DATA AND SPECIFICATIONS (SDS)	5	H
ACCELERATOR CONTROL SYSTEM	3	Accelerator Control	5	I

J

K

L

M

N

O

P

PRECAUTIONS

< PRECAUTION >

PRECAUTION

PRECAUTIONS

Precaution for Supplemental Restraint System (SRS) "AIR BAG" and "SEAT BELT PRE-TENSIONER"

INFOID:000000011934781

The Supplemental Restraint System such as "AIR BAG" and "SEAT BELT PRE-TENSIONER", used along with a front seat belt, helps to reduce the risk or severity of injury to the driver and front passenger for certain types of collision. Information necessary to service the system safely is included in the SR and SB section of this Service Manual.

WARNING:

- To avoid rendering the SRS inoperative, which could increase the risk of personal injury or death in the event of a collision which would result in air bag inflation, all maintenance must be performed by an authorized NISSAN/INFINITI dealer.
- Improper maintenance, including incorrect removal and installation of the SRS, can lead to personal injury caused by unintentional activation of the system. For removal of Spiral Cable and Air Bag Module, see the SR section.
- Do not use electrical test equipment on any circuit related to the SRS unless instructed to in this Service Manual. SRS wiring harnesses can be identified by yellow and/or orange harnesses or harness connectors.

PRECAUTIONS WHEN USING POWER TOOLS (AIR OR ELECTRIC) AND HAMMERS

WARNING:

- When working near the Airbag Diagnosis Sensor Unit or other Airbag System sensors with the Ignition ON or engine running, DO NOT use air or electric power tools or strike near the sensor(s) with a hammer. Heavy vibration could activate the sensor(s) and deploy the air bag(s), possibly causing serious injury.
- When using air or electric power tools or hammers, always switch the Ignition OFF, disconnect the battery and wait at least three minutes before performing any service.

ACCELERATOR CONTROL SYSTEM

< REMOVAL AND INSTALLATION >

REMOVAL AND INSTALLATION

ACCELERATOR CONTROL SYSTEM

Exploded View

INFOID:000000011934782

ACC

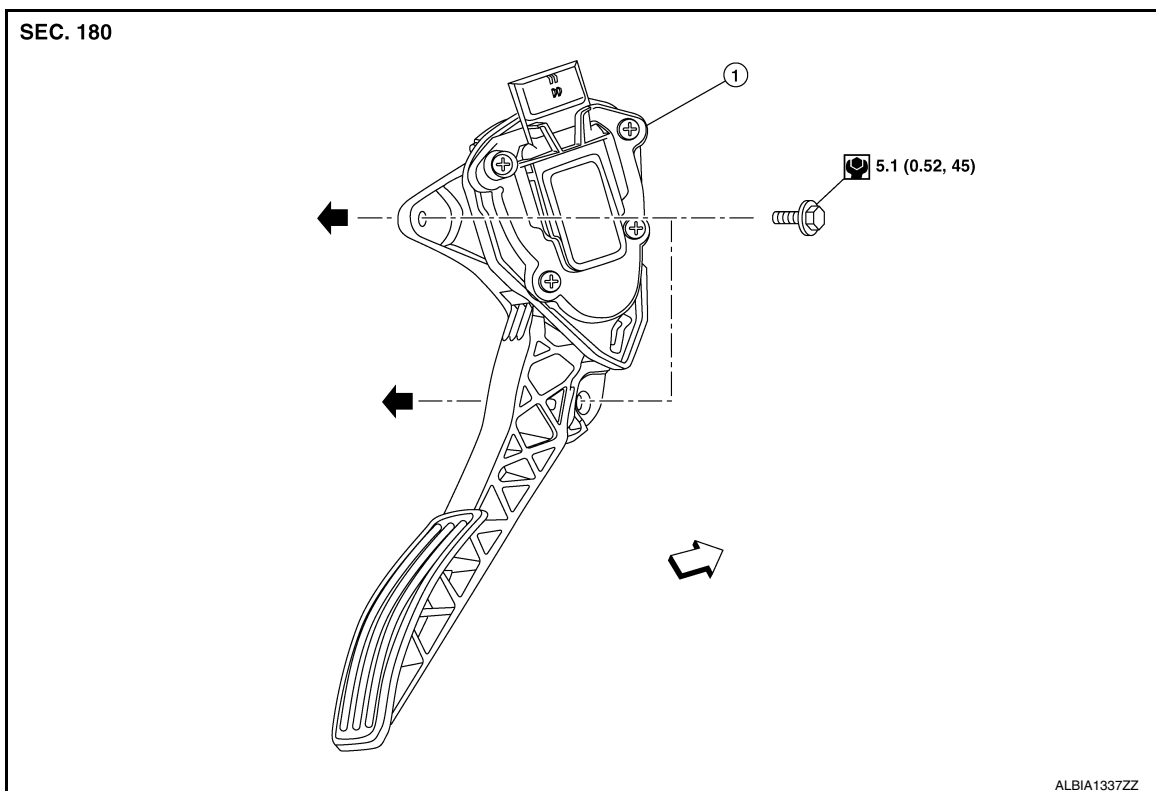

1. Accelerator pedal and accelerator position sensor assembly ← Front ← To brake pedal assembly

Removal and Installation

INFOID:000000011934783

REMOVAL

1. Disconnect the harness connector from the accelerator pedal and accelerator position sensor assembly.
2. Remove the two bolts from the accelerator pedal and accelerator position sensor assembly.
3. Remove the accelerator pedal and accelerator position sensor assembly.

CAUTION:

- Do not disassemble the accelerator pedal and accelerator position sensor assembly. Do not remove the accelerator pedal position sensor from the accelerator pedal and accelerator position sensor assembly.
- Avoid impact from dropping during handling.
- Keep the accelerator pedal and accelerator position sensor assembly away from water.

INSTALLATION

Installation is in the reverse order of removal.

ACCELERATOR CONTROL SYSTEM

< REMOVAL AND INSTALLATION >

- Align and install the accelerator pedal and accelerator position sensor assembly (1) with locating pins (C) in the locating pin holes (D).

(A) : Front view

(B) : Side view

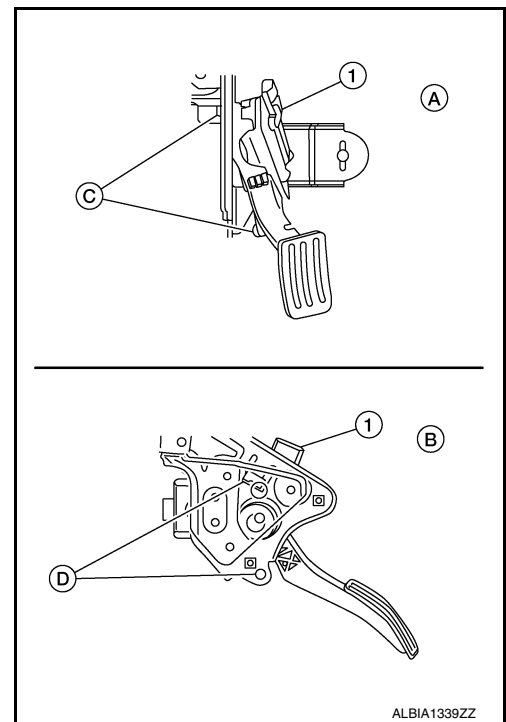

- Depress and release the accelerator pedal to verify that it returns quickly and smoothly to the original released position.
- Check that the accelerator pedal travels through the full specified distance of accelerator pedal stroke.

Accelerator pedal stroke (A) : Refer to [ACC-5, "Accelerator Control"](#).

- Check the pedal height difference between accelerator and brake.

Pedal height difference between accelerator and brake (B) : Refer to [ACC-5, "Accelerator Control"](#).

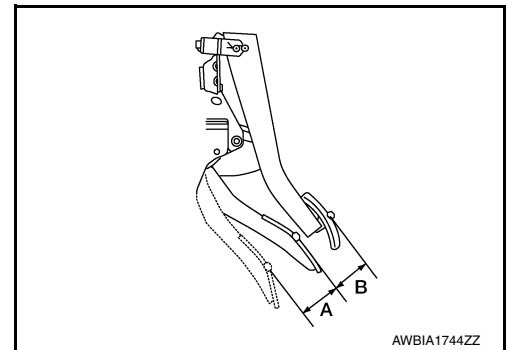

- If the accelerator pedal does not meet specified values, check the brake pedal. Refer to [BR-12, "Inspection"](#).

CAUTION:

- Whenever the harness connector is disconnected from the accelerator pedal and accelerator position sensor assembly, perform the ACCELERATOR PEDAL RELEASED POSITION LEARNING procedure. Refer to [EC-158, "Description"](#).
- The accelerator pedal should operate smoothly without catching when the accelerator pedal operating force is released. The accelerator pedal should return smoothly to the fully released position. The spring should be free from damage.

SERVICE DATA AND SPECIFICATIONS (SDS)

< SERVICE DATA AND SPECIFICATIONS (SDS)

SERVICE DATA AND SPECIFICATIONS (SDS)

SERVICE DATA AND SPECIFICATIONS (SDS)

Accelerator Control

INFOID:0000000011934784

ACC

Unit: mm (in)

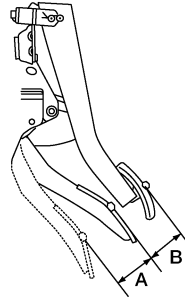

AWBIA1744ZZ

Accelerator pedal stroke (A)	50.5 - 53.5 (1.99 - 2.11)
Pedal height difference between accelerator and brake (B)	35 - 45 (1.38 - 1.77)